

OIL RECEIVER - VERTICAL

ORVS-1008 VERTICAL OIL RECEIVER 0,8 l

- Suitable for all **CFC**, **HFC** and **HCFC** refrigerants.
- Working temperature: **-10°C** to **+100°C**.
- Maximum working pressure: **32 bar**.
- Also available with sight glass and safety relief valve upon request
- **PED** and **CE** certified.
- Diameter: 101 mm.
- Equipped with 1/4" male flare top connection with schrader valve and 1/4" male flare side connection without schrader valve.

Other receivers available upon request.

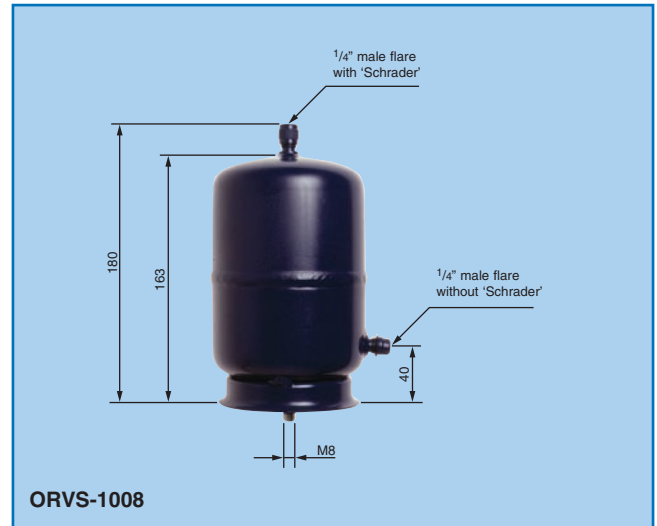

LIQUID RECEIVERS

- LRV-1018** VERTICAL LIQUID RECEIVER 1,8 l
- LRV-1039** VERTICAL LIQUID RECEIVER 3,9 l
- LRV-1092** VERTICAL LIQUID RECEIVER 9,2 l

SPECIFICATIONS

- Suitable for all **CFC**, **HFC** and **HCFC** refrigerants.
- Working temperature: **-10°C** to **+100°C**.
- Maximum working pressure: **32 bar**.
- Also available with connection for sight glass and safety relief valve upon request.
- **PED - CE certified**.

DIMENSIONS

Part Number	A	B	C	D	E	F
LRV-1018	101	252	66	140	Ø 8 x 1	25
LRV-1039	121	420	77	276	Ø 10 x 1	24
LRV-1092	168	487	92	295	Ø 12 x 1	35

